

Isolated Digital Input Board for PCI (Internal power supply)

PI-32B(PCI)H



* Specifications, color and design of the products are subject to change without notice.

Features

A different external power supply can be used for each common pin as it is shared by 16 channels.

The PCI bus (personal computer) and the input interface are isolated from each other by an Optocoupler, offering good noise immunity.

You can use all of the input signals as interrupt inputs. You can also select the interrupt trigger edge of the input signal.

The board has a digital filter feature to prevent noise or chatter from causing erroneous inputs.

The board carries an Optocoupler driving power supply. You can select whether to use the internal power supply or an external power supply.

This board is a PCI-compliant interface board for input of digital signals.

The PC can be used to input the on/off state of a switch and to control a relay.

This product can input up to 32 channels.

Using the bundled driver library package [API-PAC(W32)], you can create Windows application software for this board in your favorite programming language supporting Win32 API functions, such as Visual Basic or Visual C/C++.

* The contents in this document are subject to change without notice.

* Visit the CONTEC website to check the latest details in the document.

* The information in the data sheets is as of April, 2018.

Specification

Item	Specification
Input section	
Input format	Optocoupler isolated input (Compatible with current sink output)(Negative logic *1)
Number of input signal channels	32 channels (all available for interrupts) (One common power supply per 16 channels)
Input resistance	4.7kΩ
Input ON current	2.0mA or more
Input OFF current	0.16mA or less
interrupt	32 interrupt input signals are arranged into a single output of interrupt signal INTA. An interrupt is generated at the rising edge (HIGH-to-LOW transition) or falling edge (LOW-to-HIGH transition).
Response time	200μsec within
Common section	
I/O address	Any 32-byte boundary
Interruption level	1 level use
Max. board count for connection	16 boards including the master board
External circuit power supply	12 - 24VDC(±10%)
Internal power	12VDC 240mA *2
Power consumption	5VDC 1200mA (Max.) (Using the internal power) 5VDC 300mA (Max.) (Using the External power)
Operating condition	0 - 50°C, 10 - 90%RH (No condensation)
Allowable distance of signal extension	Approx. 50m (depending on wiring environment)
PCI bus specification	32bit, 33MHz, Universal key shapes supported *3
Dimension (mm)	176.41 (L) x 105.68(H)
Weight	150g
Standard	VCCI Class A, CE Marking (EMC Directive Class A, RoHS Directive)

*1 Data "0" and "1" correspond to the High and Low levels, respectively.

*2 When the internal power supply is used, the input section consumes a maximum of 84 mA and thus the output current to be supplied from the board is 156 mA.

*3 This board requires +5V power supply from expansion slots (it does not operate in the environment of only +3.3V power supply).

Board Dimensions

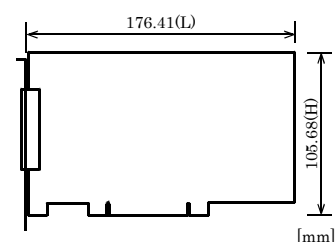

The standard outside dimension (L) is the distance from the end of the board to the outer surface of the slot cover.

Support Software

Windows version of digital I/O driver API-DIO(WDM)/API-DIO(98/PC)

[Stored on the bundled disk driver library API-PAC(W32)]

The API-DIO(WDM) is the Windows version driver library software that provides products in the form of Win32 API functions (DLL). Various sample programs such as Visual Basic and Visual C++, etc and diagnostic program *1 useful for checking operation is provided.

For more details on the supported OS, applicable language and new information, please visit the CONTEC's Web site.

Linux version of digital I/O driver API-DIO(LNX)

[Stored on the bundled disk driver library API-PAC(W32)]

The API-DIO(LNX) is the Linux version driver software which provides device drivers (modules) by shared library and kernel version. Various sample programs of gcc are provided.

For more details on the supported OS, applicable language and new information, please visit the CONTEC's Web site.

LabVIEW-support data acquisition library DAQfast for LabVIEW

(Available for downloading (free of charge) from the CONTEC web site.)

This is a data collection library to use in the LabVIEW by National Instruments. With Polymorphic VI, our design enables a LabVIEW user to operate seamlessly. Our aim is that the customers to perform easily, promptly what they wish to do.

For more details on the library and download of DAQfast for LabVIEW, please visit the CONTEC's Web site.

Data acquisition library for LabVIEW VI-DAQ (Available for downloading (free of charge) from the CONTEC web site.)

This is a VI library to use in National Instruments LabVIEW. VI-DAQ is created with a function form similar to that of LabVIEW's Data Acquisition VI, allowing you to use various devices without complicated settings.

For more details on the library and download of VI-DAQ, please visit the CONTEC's Web site.

Packing List

- Board [PI-32B(PCI)H] ...1
- First step guide ... 1
- Disk *1 [API-PAC(W32)] ...1
- Warranty Certificate...1
- Serial Number Label...1

*1 The bundled disk contains the driver software and User's Guide.

Accessories (Option)

- Screw Terminal (M3 x 37P) : EPD-37A *1*2
- Screw Terminal (M3.5 x 37P) : EPD-37 *1
- General Purpose Terminal : DTP-3A *1
- Termination Panel : DTP-4C *1
- Signal Monitor for Digital I/O : CM-32L *1

*1 A PCB37P or PCB37PS optional cable is required separately.

* Check the CONTEC's Web site for more information on these options.

Cable & Connector (Option)

- Flat Cable with a 37-Pin D-type Connectors on 2Ends
 - : PCB37P-1.5 (1.5m)
 - : PCB37P-3 (3m)
 - : PCB37P-5 (5m)

- Shielded cable with two 37-pin D- Type connectors
 - : PCB37PS-0.5P (0.5m)
 - : PCB37PS-1.5P (1.5m)
 - : PCB37PS-3P (3m)
 - : PCB37PS-5P (5m)

- Flat Cable with a 37-pin D-type Connector
 - : PCA37P-1.5 (1.5m)
 - : PCA37P-3 (3m)
 - : PCA37P-5 (5m)

- Shielded Cable with Two 37-pin D-Type Connectors
 - : PCA37PS-0.5P (0.5m)
 - : PCA37PS-1.5P (1.5m)
 - : PCA37PS-3P (3m)
 - : PCA37PS-5P (5m)

Block Diagram

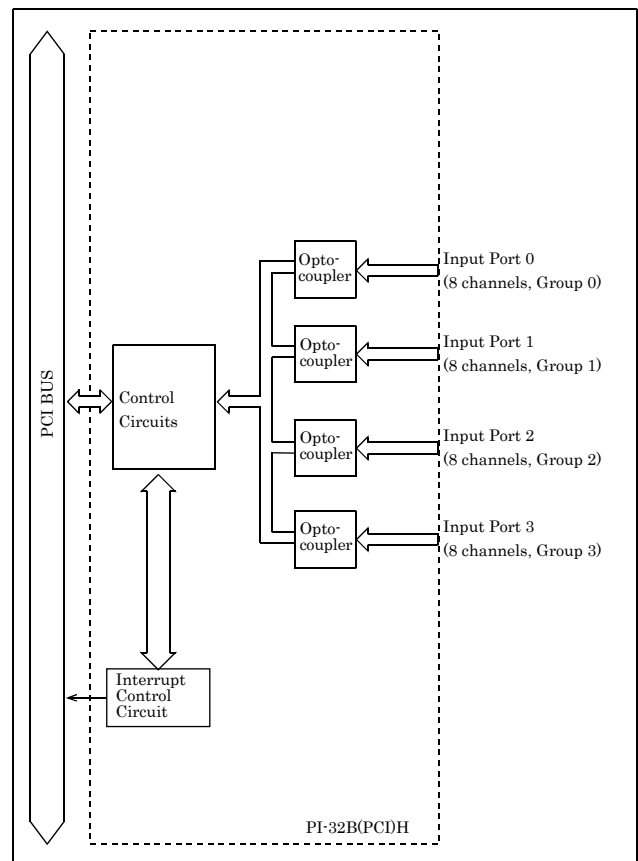

Using the On-board Connectors

Connecting a Device to a Connector

To connect an external device to this board, plug the cable from the device into the interface connector shown below.

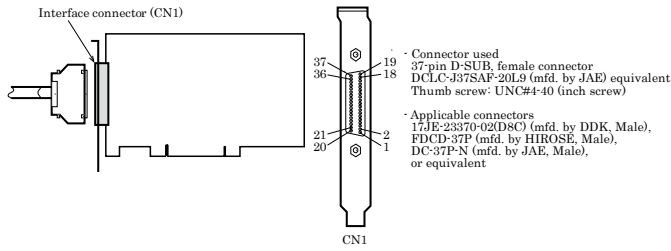

Connector Pin Assignment

Pin Assignments of Interface Connector

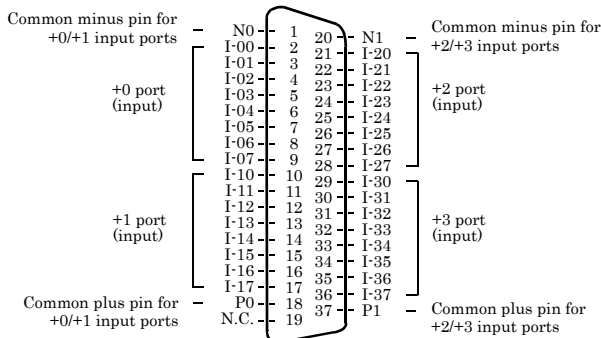

All of I-00 - I-37 can be used as interrupt inputs.

I-00 - I-37	32 input signal pins. Connect output signals from the external device to these pins.
P0, P1	When the external power supply is selected, its positive side is connected to this pin. When the internal power supply is used, this pin outputs power at +12 V. These pins are common to 16 input signal pins.
N0, N1	When the external power supply is selected, its negative side is connected to this pin. When the internal power supply is selected, this pin serves as the ground. These pins are common to 16 input signal pins.
N.C.	This pin is left unconnected.

Connect the input signals to a device which can be current-driven, such as a switch or transistor output device. The board inputs the ON/OFF state of the current-driven device as a digital value.

Input Circuit

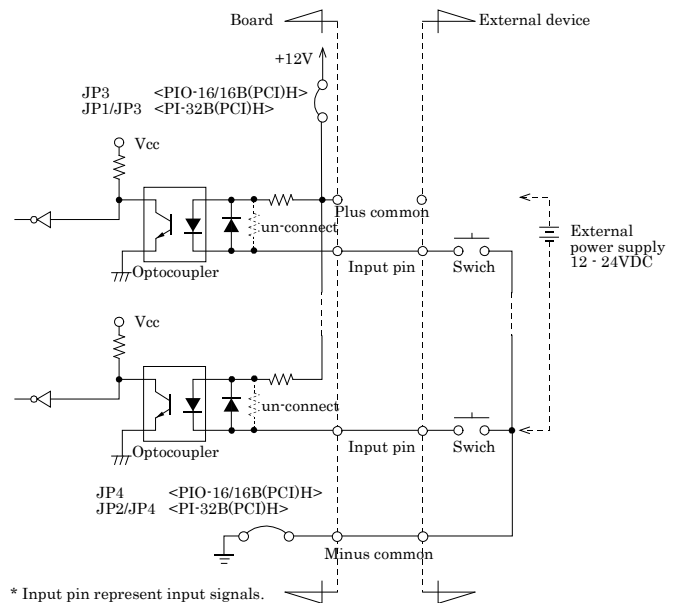

* Input pin represent input signals.

The input circuit of this board is illustrated in the image above. The signal inputs are isolated by the Optocoupler (ready to accept current sinking output signals). To drive the input section of the board, therefore, the on-board internal power supply must be used or an external power supply is required. The power requirement for each input pin is about 5.1 mA at 24 VDC (about 2.6 mA at 12 VDC).

CAUTION

See the "Selecting the internal or external power supply" section to connect the jumpers depending on the power supply to be used.

Connecting a Switch

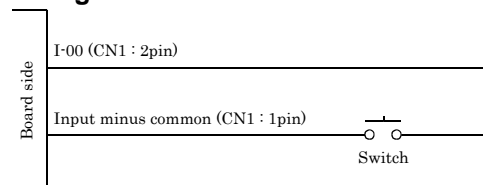

When the switch is ON, the corresponding bit contains 1.
When the switch is OFF, by contrast, the bit contains 0.

Connecting the Sink Type Output and Sink Output Support Input

The following example shows a connection between a sink type output (output board) and a sink output support input (input board). Refer to this connection example when you connect such boards to each other.

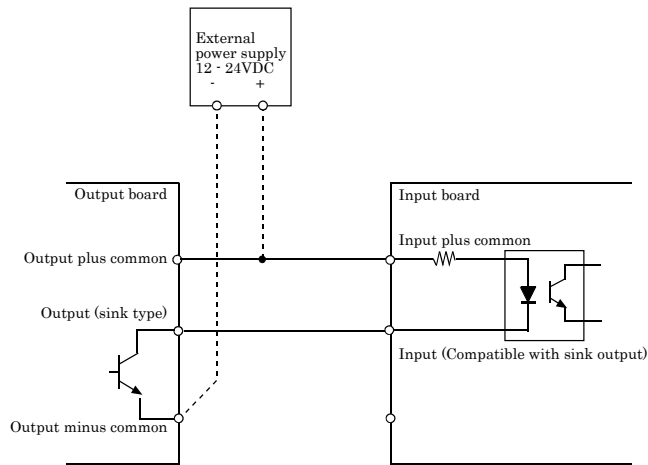

Differences between the PI-32B(PCI)H and PI-32B(PCI)

This product is connector-pin compatible with the conventional PI-32B(PCI) but has the following differences from it:

- (1) Different in the number of input signals available to interrupt requests

PI-32B(PCI)H	: All of 32 channels
PI-32B(PCI)	: 4 channels
- (2) Different in the expression to calculate the digital filter time (n: setting value)

PI-32B(PCI)H	: $2^n / (8 \times 10^6)$
PI-32B(PCI)	: $2^n / (16 \times 10^6)$
- (3) Different in interrupt level resource allocation

PI-32B(PCI)H	: Automatically allocates on interrupt level.
PI-32B(PCI)	: Uses a jumper switch to select whether to allocate interrupt levels.
- (4) Different in board dimensions

PI-32B(PCI)H	: 176.41(L) x 105.68(H) mm
PI-32B(PCI)	: 176.41(L) x 106.68(H) mm